

MODEL : BT-Mini

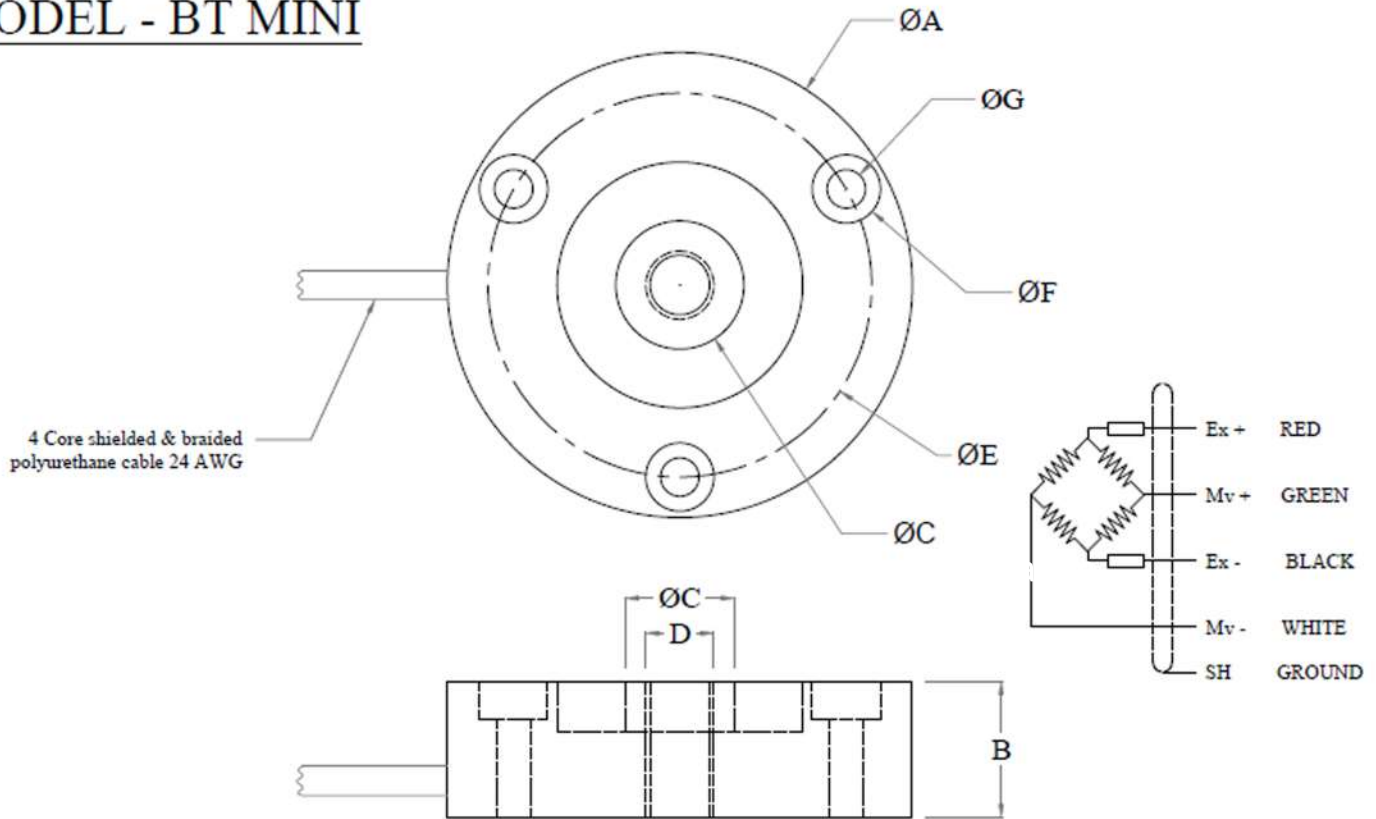

Dimension

MODEL - BT MINI



Cap. Kg.	A	B	C	D	E	F	G
500 / 1000	54.5	16	15	M8x1.25	45	8	4.5

All Dimensions are in mm.

MODEL : BT-Mini

Performance Data

Capacity Range (in Kg)	500/1000
Capacity Range (in tf)	
Nominal Sensitivity (mv/V)	1.5±0.25%
Zero Signal Tolerance	0 ± 2%
Input Resistance	350±5 Ω
Output Resistance	350±3 Ω
Recommended Excitation Voltage	12 VDC
Maximum Excitation Voltage	18 VDC
Linearity Deviation (as % of Full Scale)	< ± 0.025
Repeatability (as % of Full Scale)	< ± 0.025
Hysteresis (as % of Full Scale)	< ± 0.025
Creep (as % of Full Scale) in 30 min	< ± 0.020
Effect of Temperature on Zero (% / °C)	± 0.002
Effect of Temperature on Span (% / °C of Load)	± 0.001
Compensated Temperature Range	-10 to + 40°C
Operating Temperature Range	-20 to +70°C
Combined Error (as % Full Scale)	< ± 0.04 %
Isolation Resistance (@ 50 VDC)	> 1000 M Ω
Max. Limit Force (as % of Full Scale)	150
Breaking Force (as % of Full Scale)	300
Lateral Load Limit (as % of Full Scale)	
Protection Class	IP 67
Material of Construction	Stainless Steel

Features

- ★ Low Deflection & Creep
- ★ Allow High Permissible Dynamic Load
- ★ High Fatigue Rated & impact Resistant

Application

- ★ SPM/Level Measurement/Testing Machine (for use in compression model only) Tank Weighing / Process Automation

Sensotech

2/675, " THE PALMS", 1st Cross Street, Ranga Reddy Garden, Neelankarai, Chennai-600 041.

Tel : +91- 44 -2449 4305 / 91763 70667 / 73057 16667

Mail : sales@sensotechindia@gmail.com / sensotechindia@gmail.com

Website : www.sensomaticloadcell.net / www.sensomaticloadcell.com